

EXTRACTION UNIT BY STEAM DISTILLATION PROCESS DEVELOPED FOR MEDICAL AND AGRICULTURAL PURPOSES

Girdhar Shendre¹, Shraddha Sonone², Shivraj Raut³, Pooja Rahangdale⁴, Sujit Karekar⁵,
Chetana Parate⁶

BE Mechanical Student JDIET, Yavatmal^{1,2,5,6}

BSc. Agriculture Student MWCA, Yavatmal³

BE Chemical Student JDIET, Yavatmal⁴

krishna06022000@gmail.com¹, sononeshraddha903@gmail.com², shivamraut81@gmail.com³

Poojarahangdale1999@gmail.com⁴, sujitbkarekar30@gmail.com⁵, chetanaprate98@gmail.com⁶

Abstract: - Steam distillation is a separation process which consist of distilling water together with other volatile and non-volatile components. The steam from the boiling water carries the vapour of the volatiles to a condenser, where both are cooled and return to the liquid or solid state; while the non-volatile residues remain behind in the boiling container. If the volatiles are liquids not miscible with water, they will spontaneously form a distinct phase after condensation, allowing them to be separated by decantation or with a separator funnel. In that case, a Clevenger apparatus may be used to return the condensed water to the boiling flask, while the distillation is in progress. Alternatively, the condensed mixture can be processed with fractional distillation or some other separation technique. Steam distillation can be used when the boiling point of the substance to be extracted is higher than that of water, and the starting material cannot be heated to that temperature because of decomposition or other unwanted reactions. It may also be useful when the amount of the desired substance is small compared to that of the non-volatile residues. It is often used to separate volatile essential oils from plant material. It is however much simpler and economical than those alternatives, and remains important in certain industrial sectors.

Keywords: - *Distillation, Extraction, Organophosphates*

I INTRODUCTION

Agricultural crops are under constant assault by insect pests, making insecticides essential to reduce losses. Synthetic insecticides such as organophosphates are important, effective tools in modern crop management. However, they pose serious threats to the environment and to people. Humans come in contact with dangerous pesticides on food, in water and in the air near farms.[3] This "pesticide drift" occurs when pesticide dust and spray travel by wind to places unexposed to pesticides. Almost 98 percent of sprayed pesticides do not reach their targets. They penetrate to groundwater, pollute streams and harm wildlife, including natural predators of the targeted pests. Older pesticides such as DDT killed bald eagles, birds, fish and even people (Carson).

Many farmers will not use synthetic pesticides, and some consumers will only buy organic produce.[2] Mass production farms rely on synthetic pesticides, however, because they are cheaper than organic ones. When farmers used pesticides such

as DDT and malathion, there was little understanding of how dangerous and long-lasting these chemicals are.[8] It was only later that the degree to which these pesticides remain in the environment was discovered (Carson). Organophosphates designed to affect the brain and nervous system of insects, sometimes damage those of humans and animals [1].

Various plant species produce substances that protect them by killing or repelling the insects that feed on them. For example, the Douglas fir has a special sap that wards off beetles if it is attacked. Neem trees produce oil that alters the hormones of bugs so that they cannot fly, breed or eat (National Academy of Sciences 1992). It is possible to create effective, natural insecticides from these substances to protect crops that, unlike wild plants, may have lost their capability through cultivation to cope with pests. Natural pesticides have many advantages over synthetic ones and may be more cost-effective as a whole, considering the environmental cost of chemical alternatives. Natural pesticides are biodegradable, barely leave residues in the soil and are less likely to harm humans or animals. In

addition, they are cheaper and more accessible in less developed countries.

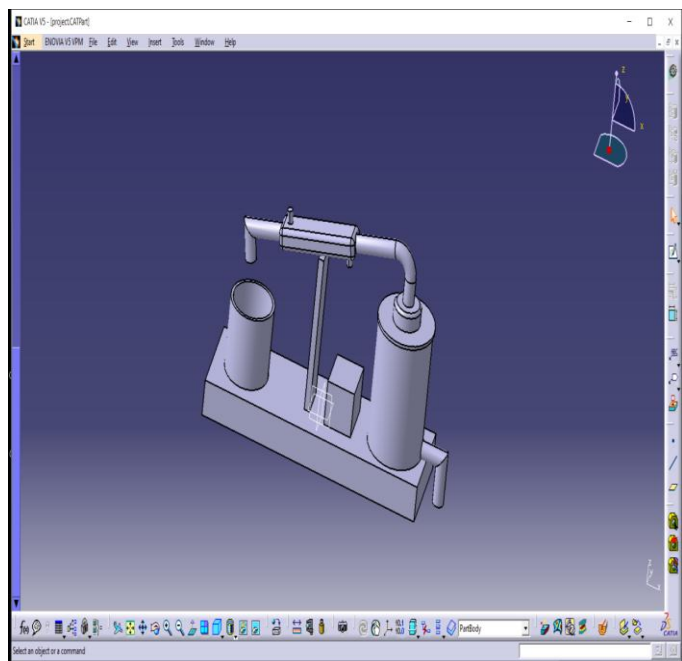

Figure 1. 3-Dimensional Sketch of Extraction Unit

Farms provide food for people and increase pest populations. Mass production of food relies on densely packed plants of the same type (monocultures), which are vulnerable to attack by insects. In natural habitats insects have to hunt for food, but a farm makes it easy for insects because the crop is isolated. Insects can cause economic devastation. In New Jersey alone, farmers lose \$290 million a year to insects. In underdeveloped countries, insect outbreaks can lead to starvation [2].

Therefore, many farmers are using plant extracts and essential oils are safe, eco-friendly and more compatible with environmental components compared to synthetic pesticides so they come under green pesticides category. Now an increasing trend in use of botanicals with more than 2400 bioactive plant species identified for their insecticidal and anti - pathogenic properties.

As a result, farmers are facing a problem how they will prepare plants extract in large quantity in very short time. This is the first time we were reporting to design the extraction unit instrument for agriculture and pharmaceutical applications.

II. LITERATURE REVIEW

Extraction of medicinal plants is a process of separating active plant materials or secondary metabolites such as alkaloids, flavonoids, terpenes, saponins, steroids and glycosides from inert or inactive material using an appropriate solvent and standard extraction procedure. Plant materials with high content of phenolic compounds and flavonoids were found to possess antioxidant properties and hence are used to treat age-related diseases such as Alzheimer's disease, Parkinsonism, anxiety and depression [6-7]. Several methods were used in the

extraction of medicinal plants such as maceration, infusion, decoction, percolation, digestion and Soxhlet extraction, superficial extraction, ultrasound-assisted and microwave-assisted extraction. In addition, thin-layer chromatography (TLC), high-performance liquid chromatography (HPLC), paper chromatography (PC), and gas chromatography (GC) were used in separation and purification of the secondary metabolites [7]. The choice of an appropriate extraction method depends on the nature of the plant material, solvent used, pH of the solvent, temperature and solvent to sample ratio. It also depends on the intended use of the final products [8-9]. This study aimed to assess various solvents of extractions, methods of extraction, fractionation, purification, phytochemical screening and identification of bioactive compounds in medicinal plants.

Earlier various works has been carried out for extract of plants. The process and instrument was very costly, hazardous, acquiring large space, having lots of disadvantages. This is the first time we were designing the extraction unit which is cost effective, ecofriendly, less hazardous, highly efficient instrument. Extraction unit is very efficient to prepare an extract of plant within a short period.

Nowadays, over use of chemical pesticides/insecticides causes environmental and health problem has been the matter of concern so plant extracts which known as biocide or green pesticides can be an alternative good source of chemical pesticides/insecticides due to their safe, eco-friendly and more compatible properties [3]. These are being used to manage the pest and minimize the yield loss. The different types of plant extract used as biocides such as neem, garlic, tobacco, kappettiya, syringe, ginger and many others are being utilized to control and manage the disease of different plants [4]. On the other hand, insects are a very huge problem in agriculture sector. To overcome this problem farmers are using the insecticide and pesticide continuously. But all farmers from all over the India are unable to buy this insecticide and pesticides are available in market to resolve the problem of insect. Nevertheless, pest insects may cause problems by damaging crops and food production [5].

Therefore, by knowing all these issues we have motivated to build such instrument which are really helpful to the farmer and resolve the existing problem.

Plant extract extraction unit instrument is very easy to handle and required less area to get installed as compare to the other existing instruments.

III. EXPERIMENTAL SETUP

The diagram of experimental setup is shown below. The experiment was conducted in a Stainless Steel Extraction Unit. It consist of one round steel drum of dome shape structure capacity of 50 lit approx which have heating coils inside to heat

, which is then connected with steel pipe which goes through one end of condenser which is used for cooling the formed steam and then from other end of condenser the water droplet receiving pipe is connected from which cooled water droplet is goes and collected in collecting drum. The thermostat is also used for measurement of rising temperature of boiling unit And cooling water unit is separated connected at bottom side which supplies continuously cooled water to condenser for cooling the steam. This unit is connected to condenser from two point, one is input and other is output. From input point the cooled water is supplied to condenser to cool down the steam and from output point the heated water is collect out in cooling Drum, then this heated water is again get cooled in cooling drum and it again supply to condenser, this process is happen continuously. The separating funnel is used for the separation of essential oil and extract water.



Figure No: 2, Actual Model of Extraction Unit

IV. EXPERIMENT PROCEDURE

Fresh leaves were cut into pieces less than 2 X 2 cm. The cut leaves put into the steel drum then add water in it until all cut leaves is drowned, then plug the power which start heating the coil. After sometimes as the temperature increases inside boiler drum which boiled the water, as when water start to boiled the steam get form which content extract of leaves which is then passes through the dome shape structure having SS Pipe connected between boiler drum and condenser. the steam start moving from boiler drum through SS pipe in condenser. In condenser the heated steam get cooled with the help of cooling water which is supply continuously from cooling unit which is connected separately, Then condense steam is from in water droplet of leaves extract . Then this water droplet is collected in

collecting drum with the help of pipe. The extract contain Essential oil at top film and the flower water at bottom.

V. CONCLUSION

Steam distillation is a special type of distillation or a separation process for temperature sensitive materials like oils, resins, hydrocarbons, etc. which are insoluble in water and may decompose at their boiling point. The temperature of the steam must be high enough to vaporize the oil present, yet not so high that it destroys the plants or burns the essential oils. Farmers are facing a problem how they will prepare plants extract in large quantity in very short time. This is the first time we were reporting to design the extraction unit instrument for agriculture and pharmaceutical applications. This is the main objective of our project. Earlier various works has been carried out for extract of plants. The process and instrument was very costly, hazardous, acquiring large space, having lots of disadvantages. This is the first time we were designing the extraction unit which is cost effective, ecofriendly, less hazardous, highly efficient instrument. Extraction unit is very efficient to prepare an extract of plant within a short period. The advantage of Steam Distillation is that it is a relatively cheap process to operate at a basic level, and the properties of oils produced by this method are not altered. As steam reduces the boiling point of a particular component of the oil, it never decomposes in this method. This method apart from being economical, it is also relatively faster than other methods.

VI ACKNOWLEDGMENT

The authors are thankful to all Professors who help for the preparation of this paper and would like to thank the anonymous reviewers and main authors for their comments which were very helpful in improving the quality and presentation of this paper.

REFERENCES

- [1]Hooper, Tony. "Push-Pull: Using Plants as Natural Pesticides." The Naked Scientists: Science Interviews. May 2008. Retrieved from <http://www.thenakedscientists.com/HTML/content/interviews/interview/910>.
- [2] Schultz, Warren, ed. Natural Insect Control: The Ecological Gardener's Guide to Foiling Pests. Twenty-First Century Gardening Series: Handbook 132. Brooklyn, NY: Brooklyn Botanic Garden, 1994.
- [3] Amin R., Sarker B.C., Adhikary S.K., Sultana S. and Zubair T. (2013) Effect of Some Botanical Extracts and Cow's Urine on Sclerotiumrolfsii Causal Agent of Foot And Root Rot of Betel Vine. The International Journal of Engineering and Science (IJES). 2(9):77-82.
- [4]Ateyyat M.A., Al-Mazraawi M.S., Abu-Rjai T. and Shatnawi M.A. (2009) Aqueous extracts of some medicinal

plants are as toxic as imidacloprid to the sweet potato whitefly, Bemisia tabaci. *Journal of Insect Science*.9(15).

[5]Barman D., Nath N., Rao S. and Barman B. (2014) Bioresource Utilization in the Management of Insect and Pest in Rice Cultivation by Garo Tribe of West Garo Hill District, Meghalaya. *Int. J. Pure App. Biosci.* 2(3):298-304.

[6]Azwanida NN. A review on the extraction methods use in medicinal plants, principle, strength, and limitation. *Med Aromat Plants* 2015;4:196.

[7]Pandey A, Tripathi S. Concept of standardization, extraction, and pre-phytochemical screening strategies for herbal drug. *J Pharmacogn Phytochem* 2014;2:115-9.

[8]Doughari J. H. Phytochemicals: Extraction methods, basic structures, and mode of action as potential chemotherapeutic agents, phytochemicals—a global perspective of their role in nutrition and health. In: *A Global Perspective of Their Role in Nutrition and Health*. Venketeshwer R. Editor. InTech; 2012. Available from: www.intechopen.com. [Last accessed 2019 Jun. 10].

[9]Sasidharan S, Chen Y, Saravanan D, Sundram KM, Yoga Latha L. Extraction, isolation and characterization of bioactive compounds from plants' extracts. *Afr J Tradit Complement Altern Med* 2011;8:1-10.